

EchoPod® DL24

Multi-Function Ultrasonic Liquid Level Transmitter



Application

The general purpose ultrasonic transmitter provides continuous level measurement up to 9.8' (3m) with a 4-20 mA signal output and four relays, and is configured via our free WebCal® software. Each relay is fully configurable for automatic fill, empty or alarm functions, and the embedded level controller may lower cost by replacing external control hardware. Select this sensor for small tanks with non-foaming, non-condensing or highly vaporous media such as chemicals, water, wastewater and oil. Typical applications include IBC or drum, cooling tower, day tank, skid or machine, open channels and chemical feed.



Features

- Level detection, switch and control functions up to 9.8' (3m)
- Configuration is fast and easy via WebCal software and USB adapter
- Narrow 2" beam width and short 4" dead band optimized for small tanks
- Four programmable relays for switch, pump or valve control and fail-safety
 - 1 pump or valve with 3 alarms
 - 2 pumps lead-lag with 2 alarms
 - 2 pumps duplexing with 2 alarms
 - 4 independent switch point alarms
- PVDF transducer and 6P polycarbonate enclosure for corrosive liquids
- Automatic temperature compensation for accurate measurement

Success

About 1.3M polyethylene tanks are sold in North America each year ranging in size from 1 to 15,000 gallons. Most of these are less than 6' in height with capacities under 500 gallons. The largest markets are industrial manufacturing, municipal, agriculture and residential in chemical, water & wastewater applications. Over the past 10 years, customers have moved toward the use of smaller storage tanks with increased automation to lower cost, and mini-bulk tanks are now a major product category. Flowline has developed a multi-function sensor to meet the needs of this growing market. The DL24 EchoPod puts non-contact level measurement, relay switch and advanced control functions in the palm of your hand.



Compatible Products



LI23

DATALOOP™
Level Indicator



LI55

DATAVIEW™
Level Controller



LI40

PODVIEW™
Level Indicator

EchoPod® DL24

Multi-Function Ultrasonic Liquid Level Transmitter



Specifications

Range:	9.8' (3m)
Accuracy:	± 0.2% of range
Resolution:	0.039" (1mm)
Dead band:	4" (10cm)
Beam width:	2" (5.08cm)
Configuration:	WebCal® PC Windows® USB 2.0
Memory:	Non-volatile
Supply voltage:	24 VDC (loop)
Consumption:	0.5W
Loop resist.:	400Ω max
Signal output:	4-20 mA, two-wire
Signal invert:	4-20 mA or 20-4 mA
Signal fail-safe:	4 mA, 20 mA, 21 mA, 22 mA or hold last
Contact type:	(4) SPST relays
Contact rating:	60 VA, 1A maximum
Contact fail-safe:	Power loss: Hold last Echo loss: Open, close or hold last
Hysteresis:	Selectable
Process temp.:	F: 20° to 140° C: -7° to 60°
Temp. comp.:	Automatic
Ambient temp.:	F: -31° to 140° C: -35° to 60°
Pressure:	MWP = 30 PSI (2 bar)
Enclosure rating:	Type 6P, encapsulated, corrosion resistant & submersible
Encl. material:	Polycarbonate
Trans. material:	PVDF
Cable jacket mat:	Polyurethane
Cable type:	9-conductor, shielded
Cable length:	48" (1.2m)
Process mount:	1" NPT (1" G)
Mount gasket:	Viton®
Classification:	General purpose
Compliance:	CE, RoHS
Approvals:	cFMus

Dimensions

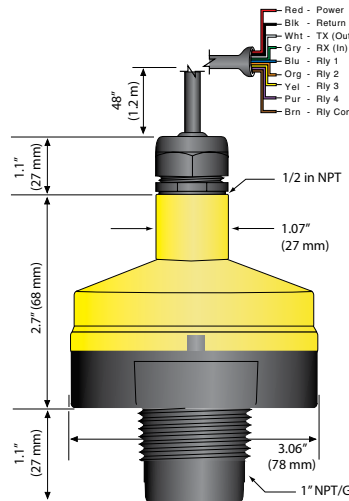

Configuration



LI99-1001

The level sensor is configurable via our free WebCal PC software and Fob USB adapter. The sensors are offered with and without Fobs. Fobs are universal and can be used to configure any WebCal compatible product. Download your free copy of WebCal in English or Chinese.

Fittings

For optimum performance, install the level sensor using the below recommended or direct equivalent fittings.

	P/N	DESCRIPTION
	LM52-1400	2" NPT x 1" NPT, PVC, schedule 40
	LM52-1800	2" NPT x 1" NPT, PVC, schedule 80
	LM52-1410	2" socket x 1" NPT, PVC, schedule 40
	LM52-1810	2" socket x 1" NPT, PVC, schedule 80
	LM52-1850	1" ANSI x 1" NPT, CPVC, schedule 80
	LM50-1001-1	1" NPT side mount bracket, PP

Ordering

DL24 -

PROCESS MOUNT (1)

- 0 NPT (US)
- 1 G (Metric)

FOB USB ADAPTER (2)

- 0 Without Fob
- 1 With Fob

NOTES

- 1) Install the level sensor using Flowline installation fittings or equivalents.
- 2) The level sensor is configured via our WebCal software and one LI99-1001 Fob USB adapter. The level sensor is offered with and without a Fob. Fobs are universal and can be used to configure any WebCal compatible product. WebCal is a free download from our website.