

OVERVIEW

The **Association for the Advancement of Medical Instrumentation (AAMI)** developed **ST108** to set the quality requirements for the different categories of water used in processing of medical devices and provides guidance as to when and where to use water of each category as well as how to verify that the water continues to meet those minimum requirements.

This standard defines multiple levels of water quality and steam purity suitable for medical device processing, and it describes the water treatment processes that can be utilized to produce water of the quality to meet each of these categories.



ANSI/AAMI ST108 WATER QUALITY RECOMMENDATIONS FOR MEDICAL DEVICE REPROCESSING

Metric	Units	Utility Water	Critical Water	Steam	Minimum Monitoring Frequencies		
					Utility Water	Critical Water	Steam
Water Use		Flushing, Washing, & Rinsing	Final Rinse & Steam	Sterilizers			
pH		6.5 - 9.5	5.0 - 7.5	5.0 - 9.2	Quarterly	Monthly	Quarterly
Total Alkalinity	Mg CaCO3/L	< 400	< 8	< 8	Quarterly	Monthly	Quarterly
Bacteria	CFU/mL	< 500	< 10	N/A	Quarterly	Monthly	N/A
Endotoxin	EU/mL	N/A	< 10	N/A	N/A	Monthly	N/A
Total Organic Carbon	Mg/L	N/A	< 1	N/A	N/A	Annually	N/A
Color & Turbidity	Visual	Colorless, clear, without sediment			Daily		
Aluminum, Copper, Iron, Manganese, & Zinc	Mg/L	< 0.1			Annually	Annually	N/A
Chloride	Mg/L	< 250	< 1	< 1	Annually	Annually	N/A
Conductivity	uS/cm	< 500	< 10	< 10	Quarterly	Daily	Quarterly
Nitrate	Mg/L	< 10	< 1	< 1	Annually	Annually	N/A
Phosphate	Mg/L	< 5	< 1	< 1	Annually	Annually	N/A
Sulfate	Mg/L	< 150	< 1	< 1	Annually	Annually	N/A
Silicate	Mg/L	< 50	< 1	< 1	Annually	Annually	N/A
Total Hardness	Mg/L	< 150	< 1	< 1	Quarterly	Monthly	Quarterly

SUMMARY OF KEY ITEMS WITHIN AAMI ST108

1. Design of the system (see process flow diagram below from AAMI ST108):
 - a. Preferably a continuous loop system with a carbon filter or chlorine destruct chemical, water softener, RO, DI, RO Tank (Conical bottom), Pump, possible UV, bacteria filter (0.2 micron), sample port, loop, and return sample port right before going back into RO tank.
 - b. It should have alarms to alert when conductivity is out of range, and tanks, membranes and filters need to be changed.
 - c. RO unit should have a “divert to drain and flush” if poor quality.
 - d. Critical water loop should be piping made of schedule 80 PVC, PP or high-density PE.
 - e. It should be its own system and not tied to another critical water application (Dialysis, lab, etc.)
 - f. It should be designed as a recirculating loop with a return velocity of 3-5 feet per second (FPS).
2. Disinfections should be done monthly, especially if testing is above limits. Ozone is recommended the most, but chlorine, sodium hypochlorite, hydrogen peroxide and peracetic acid are other alternatives. This includes the loop and RO Tank.
3. Testing limits & frequencies for Critical Water (see limits and frequencies on page one):
 - a. The ionic compounds are typically done annually unless the system is not controlled.
 - b. Daily conductivity (preferably an online sensor)
 - c. Three monthly tests (pH, hardness and alkalinity) done on a service visit or by the customer.
 - d. Monthly Heterotrophic Plate Count (HPC) and Endotoxin (both beginning of loop and right before entering RO tank). Need sample ports after final treatment in loop and right before water returns in the RO tank.

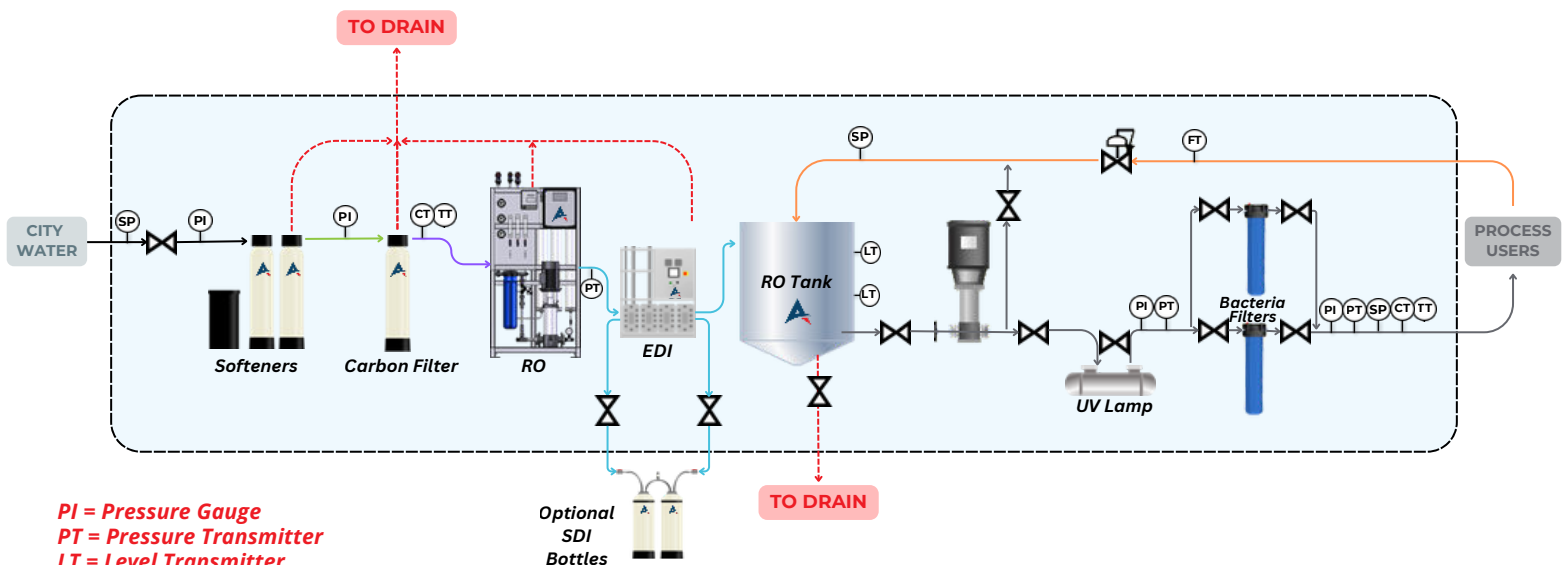

PI = Pressure Gauge
PT = Pressure Transmitter
LT = Level Transmitter
FT = Flow Transmitter
CT = Conductivity Transmitter
TT = Temperature Transmitter
SP = Sample Port

